

Solar Charge Controllers

5.6 / 6.6 / 5.0

8.8 / 8.0

Discharge Protection
Overcharge Protection
Temperature Compensation
System Voltage 12/24 V
Gassing Regulation



Please read these instructions completely before installation!

Instructions and description of controllers with overcharge and overdischarge protection, gassing regulation and temperature compensation.

In photovoltaic solar systems lead batteries are often used for storing solar current. These batteries have to be protected against overcharging and overdischarging. The Solsum controllers Solsum 5.0 / 5.6 / 6.6 / 8.0 / 8.8 fulfill both tasks in one device. They can be used for 12 and 24 V systems.

Overcharge Protection

When the battery exceeds the final charge voltage, it starts to gas. As this process is temperature dependent, the final charge voltage is adapted automatically to the ambient temperature by a built-in sensor. Strong gassing leads to an electrolyte loss and finally to the destruction of the battery. The battery is however not charged completely when the final charge voltage is reached, so that the current flow should not be interrupted. The charge controller therefore reduces the current flow into the battery just as much as that the final charge voltage is not exceeded. This procedure is called "U-charging" which is considered to be especially fast and gentle. The reduction of the current flow is effected by very quick, temporary short-circuiting (pulse width modulation) of the solar generator.

Gassing Regulation

The final charge voltage is changed in dependence with the discharge level. When a lead battery is operated without gas development for a longer time, there is the danger of a harmful acid layering. This acid layering can be avoided by limited, controlled gassing. This function is fulfilled by the gassing regulation. The gassing regulation switches off the overcharge protection until the so-called final gassing voltage is reached. Furthermore the gassing regulation increases the final charge voltage during high cyclisation. By this temperature dependent function, the battery capacity is better used.

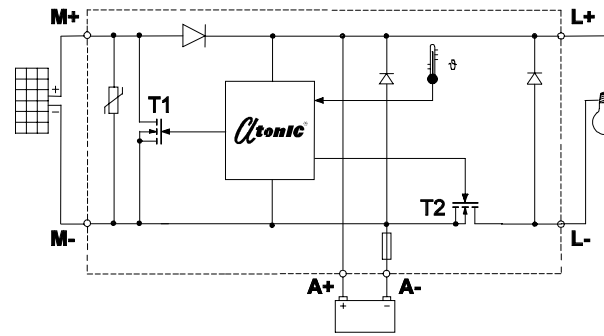

Fig. 1: Circuit Diagram

Overdischarge protection

The batteries have to be protected from overdischarge, as it would be destroyed otherwise. Therefore the charge controller protects the battery from overdischarge by disconnecting the loads when the voltage falls below the final charge voltage. After the battery has been recharged by the solar generator and the reconnection voltage is reached, the users are again reconnected.

Displays:

The controller contains a green and a LED which can change its colour from red via yellow to green in ten different colour. The green LED is on as soon as there is energy from the module. When the controller starts to limit the charge current, this LED is flashing. The LED which can change its colour shows the voltage by its colour. Before the load is switched off, this LED starts to flash fast. When the load is switched off, this LED flashes slowly.

Do not forget that the connected users do not use more current than admissible for your regulator.

Advice for Installation:

The controller has to be installed possibly near the battery and must not be exposed to direct weather conditions. The controller is to be operated in well-ventilated rooms. The connection terminals have to point downwards when it is installed. In order to activate the protective functions the controller has to be connected with solar generator, battery and users.

All system components i.e. solar generator, battery users and controller have to be coordinated concerning voltage. This is to be checked before installation! Pay attention to the correct nominal voltage! Ask your dealer when you are in doubt!

Following order has to be obeyed when installing your controller:

1. Connect the battery with the controller at the screw terminal. The biggest possible cable diameter is recommended in order to keep a voltage drop and a connection terminal heating as low as possible (see technical data). Only when the controller is installed with short circuit proof cables, an isolation of the battery cable can be omitted. Otherwise a fuse has to be inserted directly at the plus pole of the battery in order to avoid a short circuit. Both components have to be installed in the same room in near distance, as the sensor for temperature determination is integrated into the controller.
2. Connect the modules with the controller and note the correct polarity.
3. At last connect users
For installation see figure 2.

Pay attention to the correct polarity!

Sources of errors:
Inversion of battery polarity: The fuse blows, it has to be replaced by the same type.

Inversion of module polarity: This is to be avoided.

Inversion of the polarity of the load: The users (lights, radio etc.) can be damaged before the fuse blows. A huge energy quantity is stored in the battery. In the case of a short circuit, this energy can be set free within a short time and a fire at the place of the short circuit can be caused because of heat.

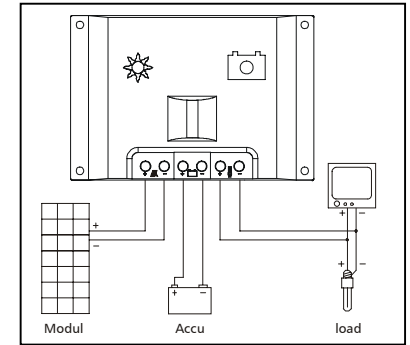

Fig. 2: Connection

Attention:

1. Avoid short circuits: danger of fire!
2. Users which may not switched off must be installed near the battery and protected by a fuse (e. g. position lights)
3. Sparkings can develop especially in direct current systems during installation and operation. Do not install PV-components in rooms where easy flammable gases mixtures can develop (e. g. by gas bottles, laquers, solvents). Consult your dealer when in doubt.

Adjustment of nominal voltage

Automatic adjustment to the system voltage when the regulator is installed.

When you pay attention to this instructions your solar system will give you many years of pleasure. The battery reaches a life of ten years or longer. As the solar module and the charge controller have a considerably higher life age, only the battery has to be exchanged. A defect battery can be recognised that although the above-mentioned charging takes place, the overdischarge protection switches off the users already after a short time.

Technical Data at 25°C:

Controller Type	5.6/6.6	8.8	5.0	8.0
Nominal Voltage	12 V			
Max. module current	6 A	8 A	5 A	8 A
Max. load current	6 A	8 A	-*	-*
Max. own consumption	4 mA			
Final charge voltage	13,7 V			
Temperature compensation	4 mV / K / cell			
Overdischarge disconnection				
Constant	11,1 V	11,1 V	-*	-*
Reconnection	12,6 V	12,6 V	-*	-*
Gassing regulation				
"Gassing active" voltage	12,4 V			
Final gassing voltage	14,4 V			
Temperature Compensation	- 3 mV / K / cell			
Fuse	7,5A	10 A	7,5 A	10 A
Admissible ambient temperature	-25 °C ... + 50 °C			
Dimensions	130 x 88 x 39 mm			
Connection terminal	2,5 mm ² / 4mm ²			
Weight	165 g			

(For 24V systems voltages are to be doubled!)

* No load disconnect. Only fused with 7,5 and 10A.