

SunWize® SW150 Solar Module

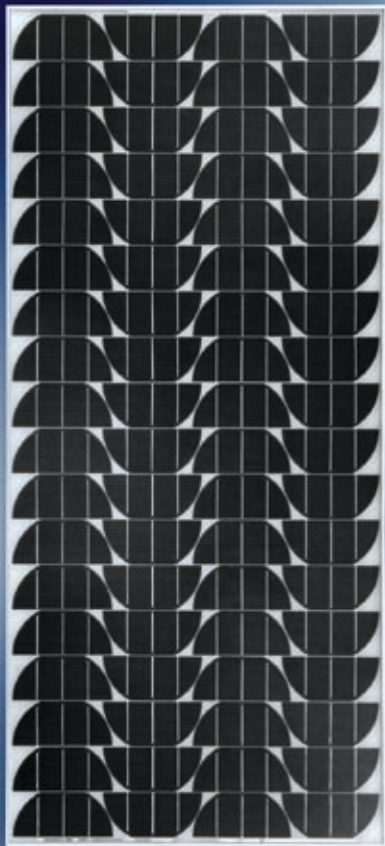

SunWize SW150 solar module

SunWize SW150, 24V solar modules deliver top-quality performance for all photovoltaic applications including rural electrification, lighting, telemetry, telecommunications, and battery charging. SunWize modules can be used in single-module and multiple-module installations and are ideal for high voltage grid-tied inverters. Each module consists of 72 solar cells connected in series providing maximum charging power. Anodized aluminum channel frames add strength and durability and are constructed to withstand constant wind speeds of 110 mph and gusts to 133 mph. SW150 modules have pre-drilled mounting holes.

FEATURES:

- Single crystalline solar cells are encapsulated and bonded to the glass in multiple layers of ethylene vinyl acetate (EVA) and laminated with a white Tedlar™ backing insuring long life in severe environmental conditions.
- The glass surface allows maximum light transmission and is impact resistant to hailstone forces up to 5 ft-lbs.
- A weather resistant junction box accommodates all wiring methods including moisture-tight strain relief connectors and electrical conduit.
- Dual bypass diodes contained within the junction box insure reliable operation.
- #10 AWG USE-2, 30" lead wires with MC™ connectors.
- SW modules are manufactured in accordance to ISO 9002 standards, ISPR certified to IEC 61215.
- All SunWize modules carry a 25-year, 80% power output warranty.

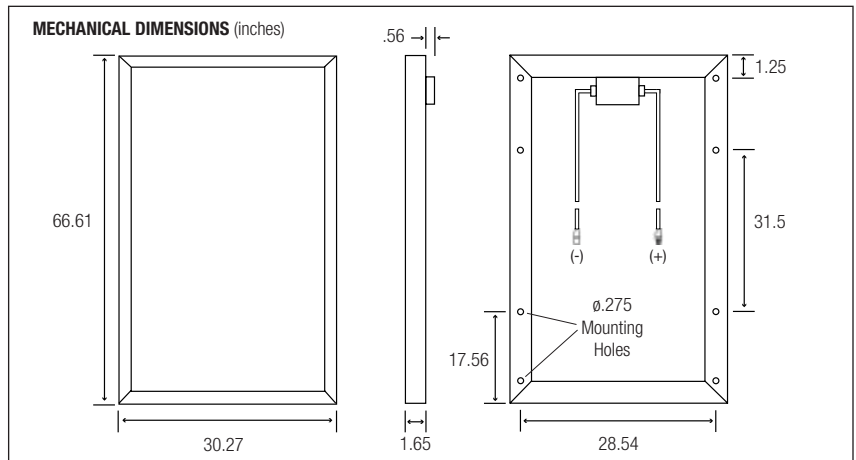

Model	Rated Power (Watts)	Rated Voltage (Vmp)	Rated Current (Imp)	Open Circuit (Voc)	Short Circuit (Isc)	Dimensions (Inches)	Unit Wgt (lbs)
SW150	150	16.7	8.99	42.0	5.11	66.61 x 30.27 x 1.65	44

ELECTRICAL SPECIFICATIONS: ±10% @25°C @ 1000W/M²

