

# STERNMOUNT MARINE TOWER KIT OWNER'S MANUAL

VERSION 1.5

Made in the USA by:

*Southwest Windpower*

1801 W. Route 66

Flagstaff, AZ 86001

(520) 779-9463

*AIR Marine is a trademark of Southwest Windpower Inc.*

## STERNMOUNT MARINE TOWER KIT

### Notes

CONGRATULATIONS! You have just purchased the most advanced marine wind turbine mounting system available. This tower has been designed to be simple to install and to reduce the vibrations that any wind turbine produces. However, it is important that you read this manual thoroughly prior to assembly. If you have any questions on proper installation or usage please contact either Southwest Windpower or your Dealer for information.

Notice: This information is believed to be reliable; however, Southwest Windpower assumes no responsibility for inaccuracies or omissions. The user of this information and product assumes full responsibility and risk. All specifications are subject to change without notice.

### Contents:

<b>Step 1: Site Evaluation</b>	<i>page 4</i>
<b>Step 2: Saddle Clamp Installation</b>	<i>page 5</i>
<b>Step 3: Mast Base Assembly</b>	<i>page 6</i>
<b>Step 4: Mast Base Installation</b>	<i>page 7</i>
<b>Step 5: Stay Base Installation</b>	<i>page 7</i>
<b>Step 6: Wiring and Final Assembly</b>	<i>page 8</i>
<b>Mast and Stay Specifications</b>	<i>page 10</i>
<b>Drill Guide Template For Poles</b>	<i>page 11</i>

## Parts List

Your new tower kit includes:	Quantity:
• Stainless steel end caps	4
• Mast vibration dampening mount (with bolt, washers, nut and bracket)	1
• Stay vibration dampening mounts	2
• Stay base bracket	2
• Mast hinge base angle brackets	2
• Mast saddle straps	4
• Mast wiring grommet	1
• $\frac{3}{8}$ "-16 x 2" stainless steel socket head screws	2
• $\frac{5}{16}$ "-18 x $\frac{3}{4}$ " stainless steel socket head screws	2
• $\frac{5}{16}$ "-18 x 1" stainless steel socket head screws	4
• $\frac{1}{4}$ "-20 x 1- $\frac{3}{4}$ " stainless steel socket head screws	4
• 8-32 x $\frac{1}{2}$ screws	2
• $\frac{3}{8}$ "-16 nylon lock nuts	2
• $\frac{5}{16}$ "-18 nylon lock nuts	6
• $\frac{1}{4}$ "-20 nylon lock nuts	4
• $\frac{3}{8}$ " stainless steel extra thick washer	2
• $\frac{3}{8}$ " lock washer	2
• $\frac{1}{8}$ " thick rubber adapter sleeve (for stainless steel towers <b>only</b> )	1
• Powder coated or stainless steel mast	1
• Powder coated or stainless steel stays	2

Please inspect the contents with the above list to familiarize yourself with all parts. *See addendum for kits not including mast or stays for correct preparation information.*

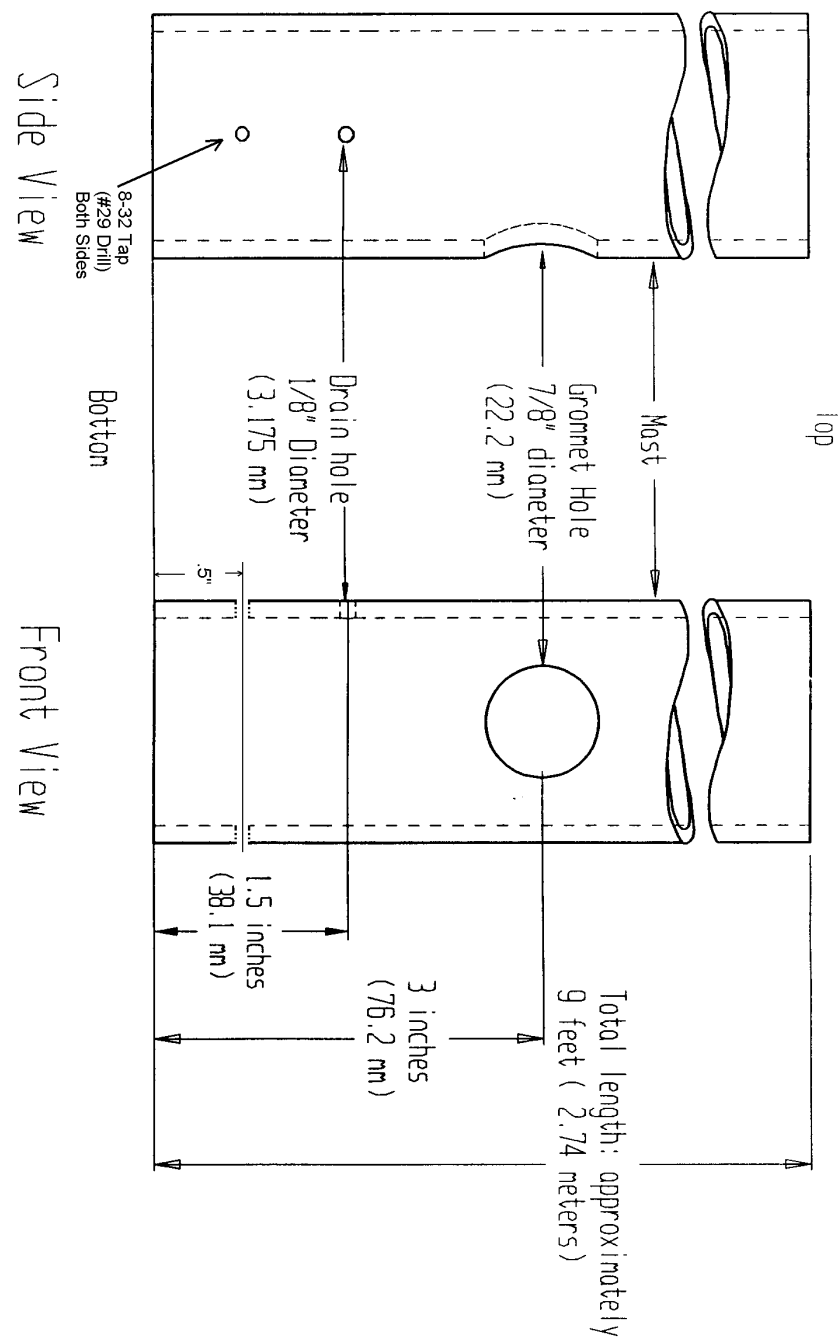

## Mast and Stay Specifications

### *For kits not including mast or stays*

If you opted to purchase a hardware kit without the mast and stays, you will need to make your own poles prior to proceeding with the installation. The materials you will need are:

- **(2) Stays** of 9-12 foot (2.7m-3.7m) lengths of 1 inch (25.4mm) **outer diameter** aluminum pipe with a wall thickness of 1/8" (3.18mm).

If stainless steel stays are desired, 1 inch (25.4mm) **outer diameter**, .095" (2.41mm) wall thickness or thicker pipe is recommended.

The stays should be long enough to support the tower structure in high wind conditions and short enough to allow for proper blade clearance. Additionally, the angle between the mast and stays should be within the range illustrated in figures 1 and 2 in the manual.

- **(1) Mast** of 9-12 feet (2.7m to 3.7m) of 1-½ schedule 40, .135" (3.5mm) wall thickness **aluminum pipe**.

**Stainless Steel** masts should be 1-½ inch, schedule 10, .10" (2.8mm) wall thickness pipe (type 304).

**NOTE:** Actual pipe outside diameter 1.9 inch (48.3mm)

### Stays

Slip an end cap onto **one** end of each stay and tighten the set screw. Use a ¼" (6.4mm) drill to make two holes in each stay, one side at a time. Use the holes in the end caps as a guide. You may need to remove any burr or sharp edge left from the drill.

### Mast

See diagram for drill sizes and locations. Insert the rubber grommet into the large 7/8" (22mm) hole. For masts with thinner walls, use the 1/8" (3.2mm) silicone adapter.

When the mast and stays have been prepared, continue with installation beginning with **Step1: Site Evaluation**.

**Note:** The mounting materials included in this kit were designed to be mounted to a wood or fiberglass deck.

**It is recommended to use lag screws or through bolts to mount the brackets to your boat. However, these are not included in your kit. The exact configuration and hardware for the attachment of the mast base plate bracket depends on the construction of your boat. You must use your judgment to determine how best to attach the brackets to your boat.**

Prior to assembly, it is a good idea to gather all the tools necessary for the installation. These include:

- power drill
- ¼" drill bit (6.4mm)
- hacksaw with a course tooth blade
- measuring tape
- silicone caulk
- hex wrenches: 7/16", 1/2", 9/16"
- hex keys: 1/8", 3/16", 7/32"
- A second person to help you with the installation process.

Once you have checked all your parts and you have gathered all the necessary tools, you are ready to begin the installation process.

## Safety and Installation Information

The three most important factors that must be taken into consideration when installing your tower are **SAFETY & SAFETY** followed by performance. It is important to realize that any wind turbine has high-speed spinning parts and it can be very dangerous if the turbine is installed improperly!

**The AIR must be installed in a place high enough so that a person cannot come in contact with the spinning blades while the turbine is in operation.**

The second important rule is to locate the AIR in a place where the turbine is free from obstructions. The more open the area around the turbine, the better performance you will receive, and the less the chance your turbine will hit something. Be especially aware of any overhead obstructions (e.g. your boom or sail rigging).

## Step 1: Site Evaluation

While evaluating your site location, keep in mind that the stays need to be mounted at least 3.5 feet (1.1m) and no more than 6.5 feet (2.0m) away from the turbine mast (see figure 1). The spread angle between the stays should be as close to 90 degrees as possible, plus or minus 20 degrees (see figure 2). If the stays are to be mounted to a vertical or steeply sloped surface, such as the bulkhead, these guidelines may not apply.

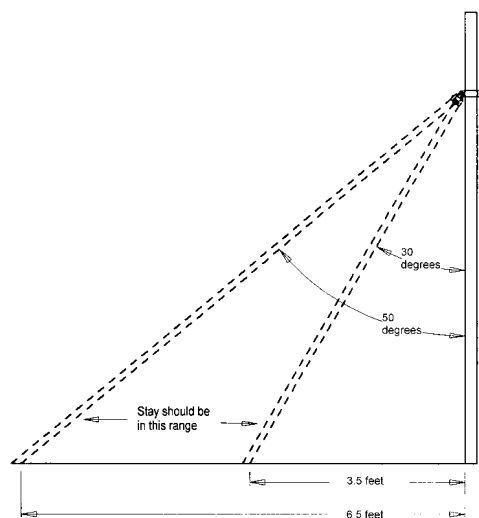

**Figure 1**-Safe distances from mast to stays.

Follow your turbine manual's instructions for attaching the turbine to the tower.

Permanently attach the end caps to the stays and bolt the bracket to the deck. Re-assemble the stay vibration mount (see figure 5). Raise the mast, with turbine attached, and secure the stays to the bracket assembly. Tighten all end cap set screws and saddle clamp hardware. Tighten the bolts at the swivel base from the nut side (see figure 4).

## Maintenance

**Periodically tighten all screws and bolts in the base brackets to make sure the tower hardware has not been loosened by vibration or wear.**

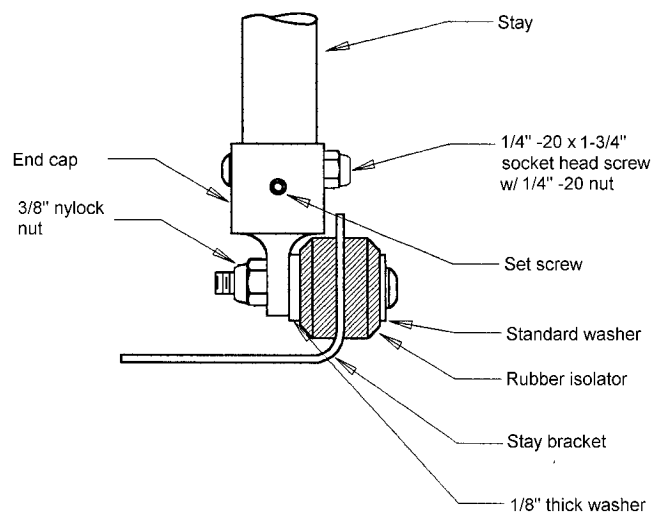

**Figure 5-**Stay mounting bracket assembly.

Have your assistant raise the mast while you hold the ends of each stay. As you do this, position each bracket base where they will provide the most rigid assembly. Determine the proper length for each stay and if necessary cut them with a hacksaw to meet the criteria specified in **Step 1:Site Evaluation**.

When each stay is in the correct position, mark the bracket hole location on the deck. Tighten the set screw in the end cap, and use a  $\frac{1}{4}$ " (6.4mm) bit to drill the bolt holes into the stay *one side at a time*. Fasten the end caps with a  $\frac{1}{4}$ "-20 x 1-1/2 socket head screw and a  $\frac{1}{4}$ "-20 nut. Drill the three bracket holes and mount the bracket assembly to the deck.

## Step 6: Wiring and Final Assembly

Insert the grommet into the  $\frac{7}{8}$ " (22.2mm) hole in the side of the tower. Run your wire through the deck from below, through the grommet and extend the wire 8 inches (20cm) above the mast. This extra wire will leave enough slack for the tower to be tilted. Use silicone caulk to seal the hole where the wires pass through.

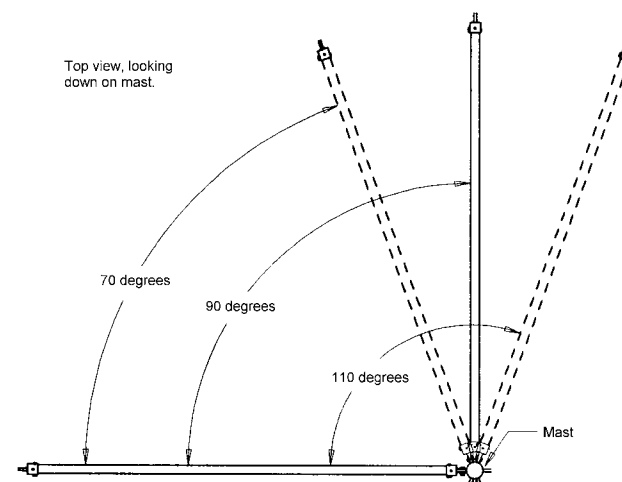

**Figure 2-**Safe angles between each stay.

Make sure there are no objects below the turbine that would allow someone to step onto and possibly come in contact with the operating turbine. It is also very important to find a secure spot on the deck or transom since the mast and stay bases will be under stress.

Most wind turbines are installation in the aft portion of the boat, either on the starboard or port side. This depends on the type of boat involved.

## Step 2: Saddle Clamp Installation

Carefully lay the mast on the deck with the bottom end (the end with the drain hole and the wire hole) closest to the base plate. Attach one end cap to the drilled end of each stay. Use a  $\frac{1}{4}$ " (6.4mm) drill bit to clear the bolt holes if necessary. Bolt this assembly to the two saddle clamps as shown in **figure 3**.

Tighten the support clamps no less than 2 feet (.61m) and no more than 3 feet (.91m) from the top of the mast and secure. **Tighten the bolt through the saddle clamp and end cap first, then tighten the other saddle clamp bolt.** Either clamp may be *anywhere* between 2-3 feet (.61m-.91m) from the top of the mast.

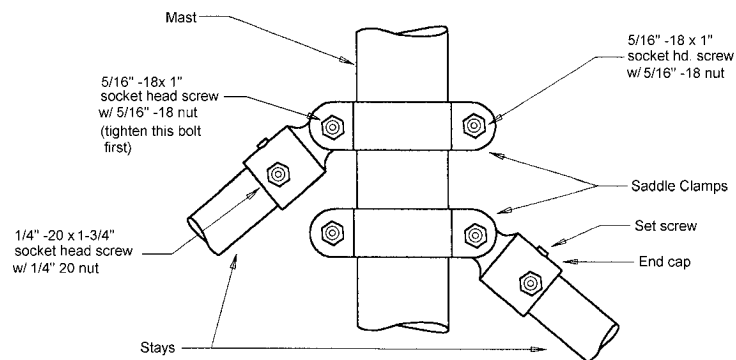

*Figure 3-Saddle clamp, end cap and stay assembly.*

### Step 3: Mast Base Assembly

Push the large noise isolator into the bottom of the mast and tighten the bolt securely. **If you are using a stainless steel mast instead of an aluminum mast, you must first slip the silicone adapter onto the rubber isolator before you insert the isolator into the bottom of the mast.** Tightening the bolt will expand the rubber isolator inside the mast, thereby securing the mast to the base.

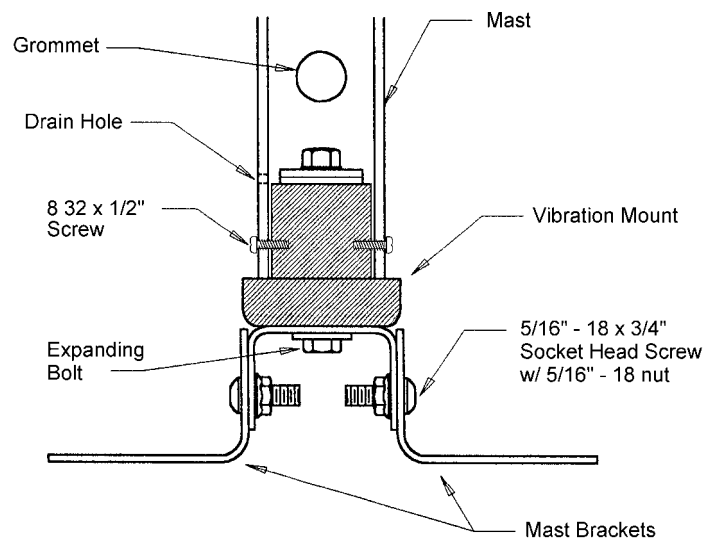

*Figure 4-Mast base assembly.*

6

After the mast base has been properly secured, thread the two screws into the side of the tower mast base and tighten.

### Step 4: Mast Base Installation

The mast base plate brackets are designed to be mounted with either the longer side to the deck as shown in figure 4, or with the short side down, and the long side bolted to the swivel bracket. Once you have located the spot where you wish to install your AIR marine, measure and mark the location on the deck or transom to mount the base plate and stays. You should determine the direction you want the mast assembly to tilt down toward and align the base plate appropriately. While holding the assembly, have your assistant mark the location of the bracket holes. Drill and fasten the base plate brackets. Pull up on the mast to test the bond between the mast and the isolator. **If the mast slips on the vibration mount, remove the mast base from the deck and repeat steps 3 and 4, making sure to securely attach the mast to the isolator.**

### Step 5: Stay Base Installation

By now you should have a good idea where the stay brackets will be positioned on the deck. Mounting the stays too far apart or too close together will result in inadequate tower support in high wind or rough seas. The angle you attach the end caps to the end of the stays depends on the angle you place the deck brackets. The easiest way to complete this task is to perform a “dry run” installation of the stays. Without drilling any holes through the ends of the stays, assemble the stay mounting brackets and insert a 3/8” bolt through each washer and each rubber insulator. Run this through each bracket and place another rubber insulator, one end cap one 1/8” thick washer and one 3/8” lock washer on each bolt (**see figure 5**). Thread a nut **LOOSELY** onto each bolt to hold the two assemblies together

7